

**PLIANT
BELLOWS**™
Expansion Joints
ENRICHED FOR FLEXIBILITY



ENRICHED
FOR



FLEXIBILITY

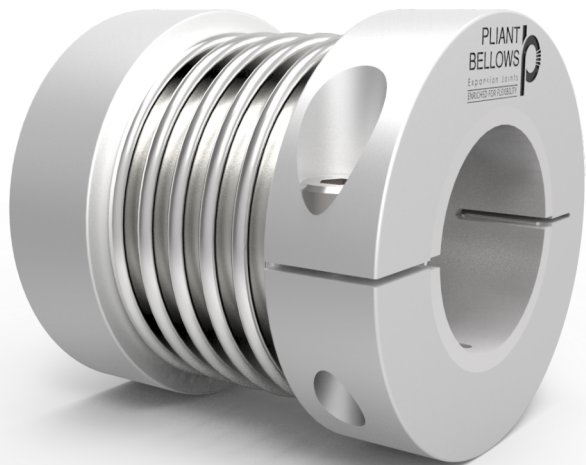

METAL BELLOW COUPLINGS

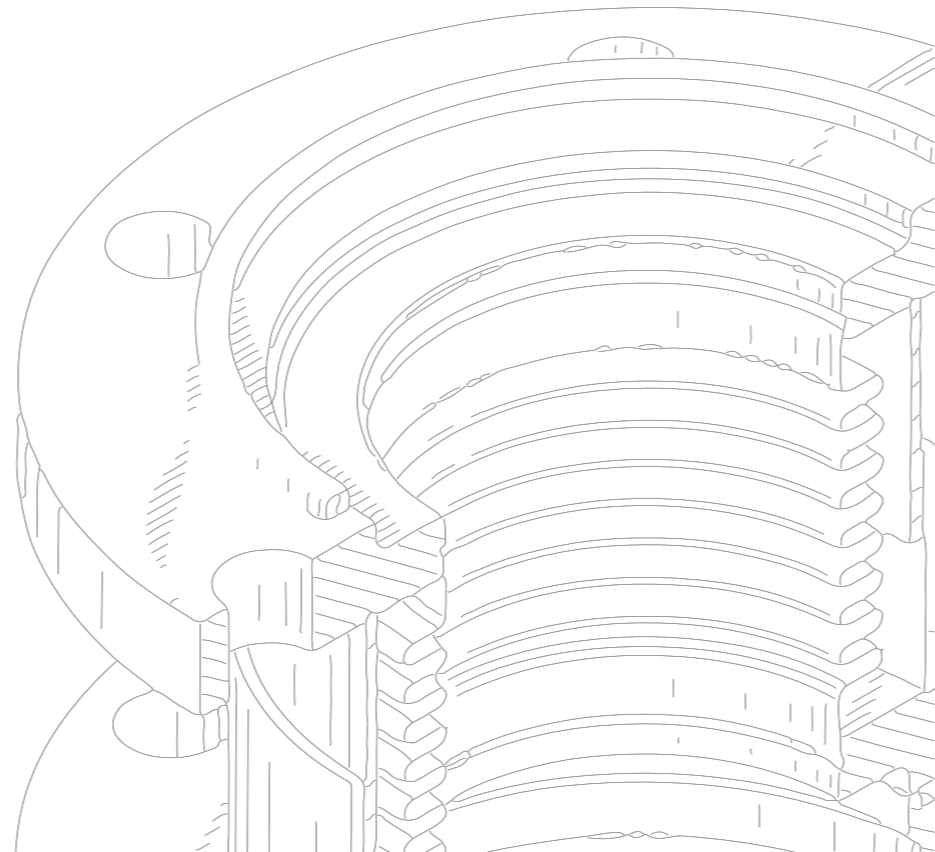
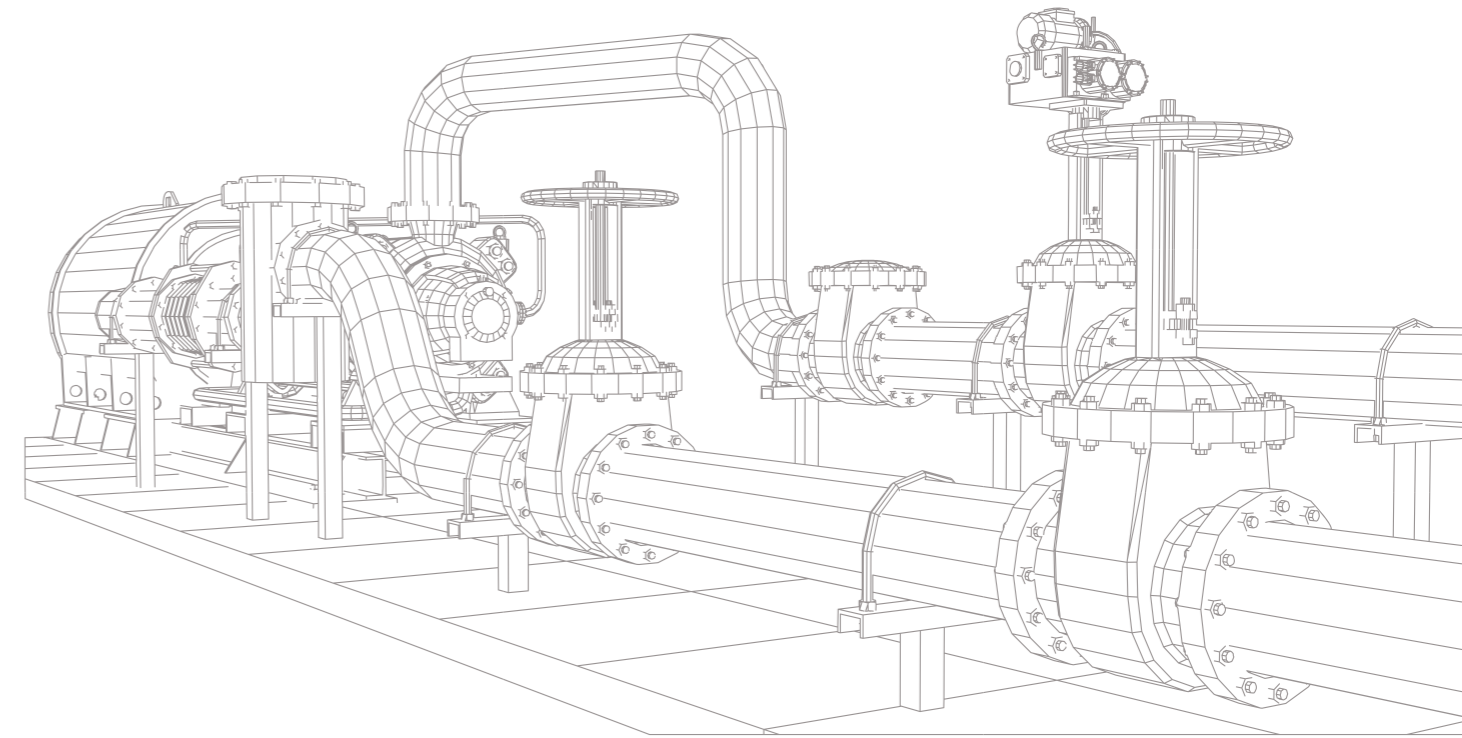
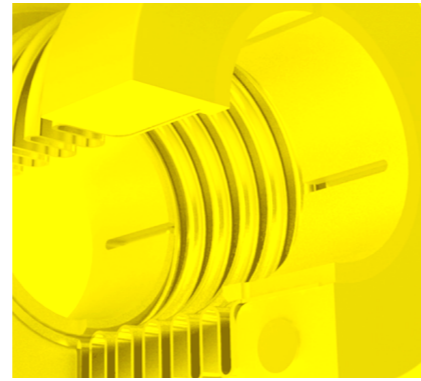

About Company

"Pliant Bellows" is the brand name of bellows manufactured by Kquality Products. The company is in the business since 1975 and has evolved to be one of the best design and manufacturing companies in and around Pune. Kquality Products was started as a job working unit to cater the needs of automotive industry. As time passed the organisation got involved in the development of import substitute products. With its commitment and hard work the company was rewarded by the Indian defence research organisation for its excellent performance.

In year 2005 the company got involved in the manufacturing of aerospace components. Today it is among the very few industries in India approved by Rolls Royce, USA for its helicopter engine division.

While its journey in serving varied organisations the company realised that there was a need of quality suppliers in the field of metal bellows and its allied products. With its rich experience in manufacturing high quality products, catering from nuclear, oil and gas to ultra high vacuum, the company launched its product, "Metal Bellow Couplings", under the brand name, "Pliant Bellows".

With the reputation of manufacturing high quality products the company decided to go for machines with world class standards. Today all the key machines are designed by the US based designers. They are manufactured to international quality standards to meet the world class product quality. Today the company is ready to serve its customers with its high quality product range.

Business Philosophy & Strengths

- As the CEO and GM are technically qualified, the general orientation of the company is towards technical excellence. The work culture has also been developed accordingly.
 - The company implements, Kaizen (Continuous Improvement) and 5 S techniques to keep the entire system up to mark.
 - To facilitate the above at operational level, experienced and qualified manpower has been employed.
 - The company has endeavoured to meet and achieve the quality standards set by the customers.
-



Systems And Certifications

Kwaliti Products is an ISO 9001:2015 certified company and is well supported by ERP Software to maintain the documentation and the entire tracking from incoming raw material to dispatch. The company has been approved by Rolls Royce for its engineering needs.

Leadership Team



Mr. Anand Uttarkar
CEO

The CEO, Mr. Anand Uttarkar is a qualified engineer with a M.S. Degree in Industrial Engineering from Texas, USA and has rich experience in the current line of activity.



Mrs. Priya Bagul-Uttarkar
General Manager

The GM, Mrs. Priya Bagul-Uttarkar is a Mechanical Engineer with a post graduation diploma in Tool & Die designing from Indo-German Tool Room and MBA in Finance from a reputed Institute in India.



Technology

Hydroforming Machine

The hydroforming machine is designed by US Designers and has been manufactured to international quality standards. Bellows formed by hydroforming process are uniform in structure with adequate dimensional accuracy. In a single step, corrugations are formed on an entire metal bellow, which increases the productivity considerably. The properties achieved by the hydroforming process are far superior as compared to mechanically drawn bellows. Metal bellows can be manufactured with a single ply or multiple plies with excellent flexibility, pressure tightness, and little wall thickness reduction.

Diameter range	[mm]	15 – 600
Ply thickness	[mm]	0.2 – 4
Tube length	[mm]	up to 1000
Internal pressure	[bar]	up to 340
Total Power	[HP]	25
Forming Time	[sec]	<60

HIGH PERFORMANCE COUPLING

- Backlash-Free Torque Transmission
- High Torsional Rigidity
- Minimal Mass Moment of Inertia
- High Misalignment Compensation Capability
- High Performance to Cost ratio due to simple construction
- Quick and Simple Installation

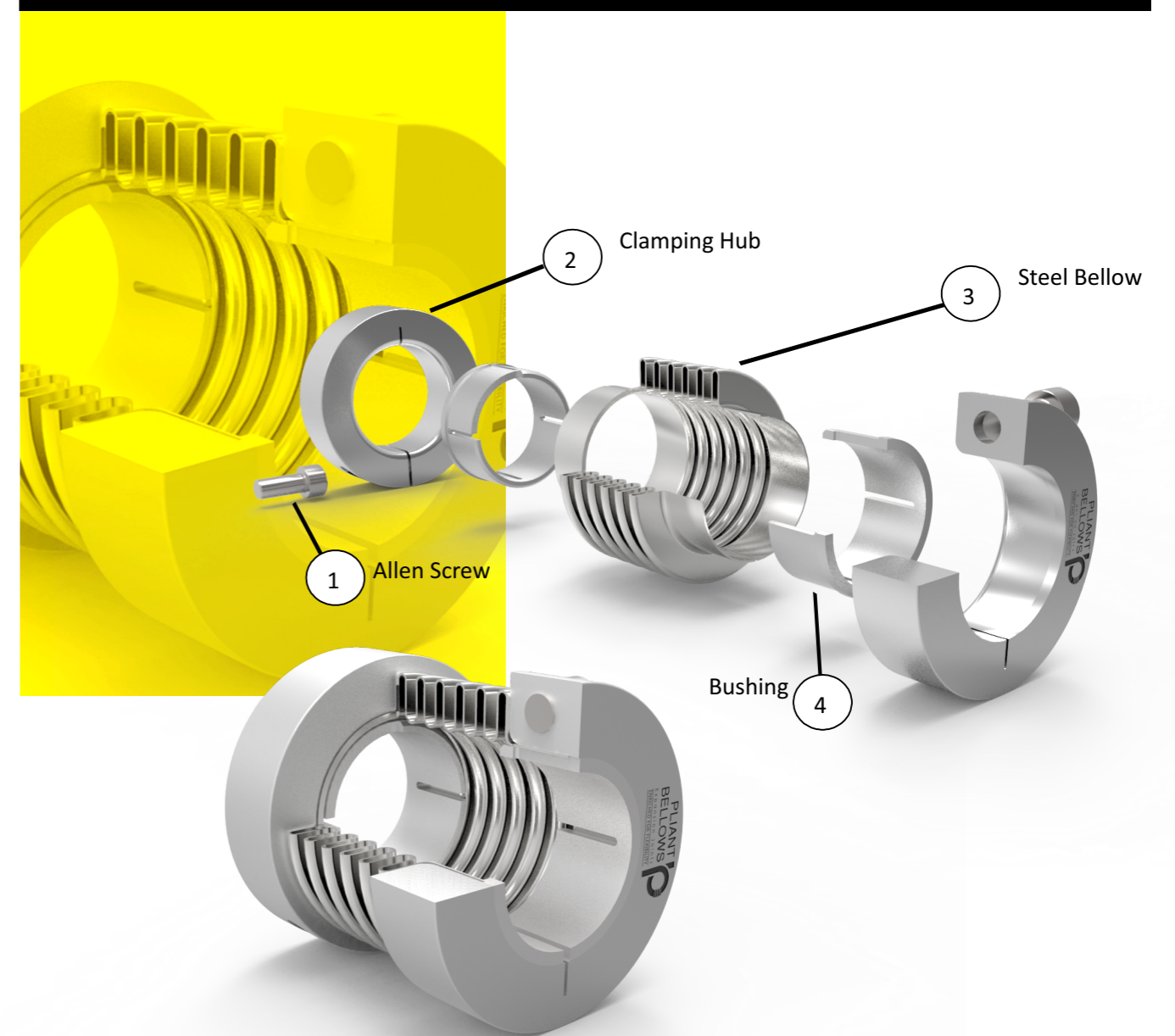
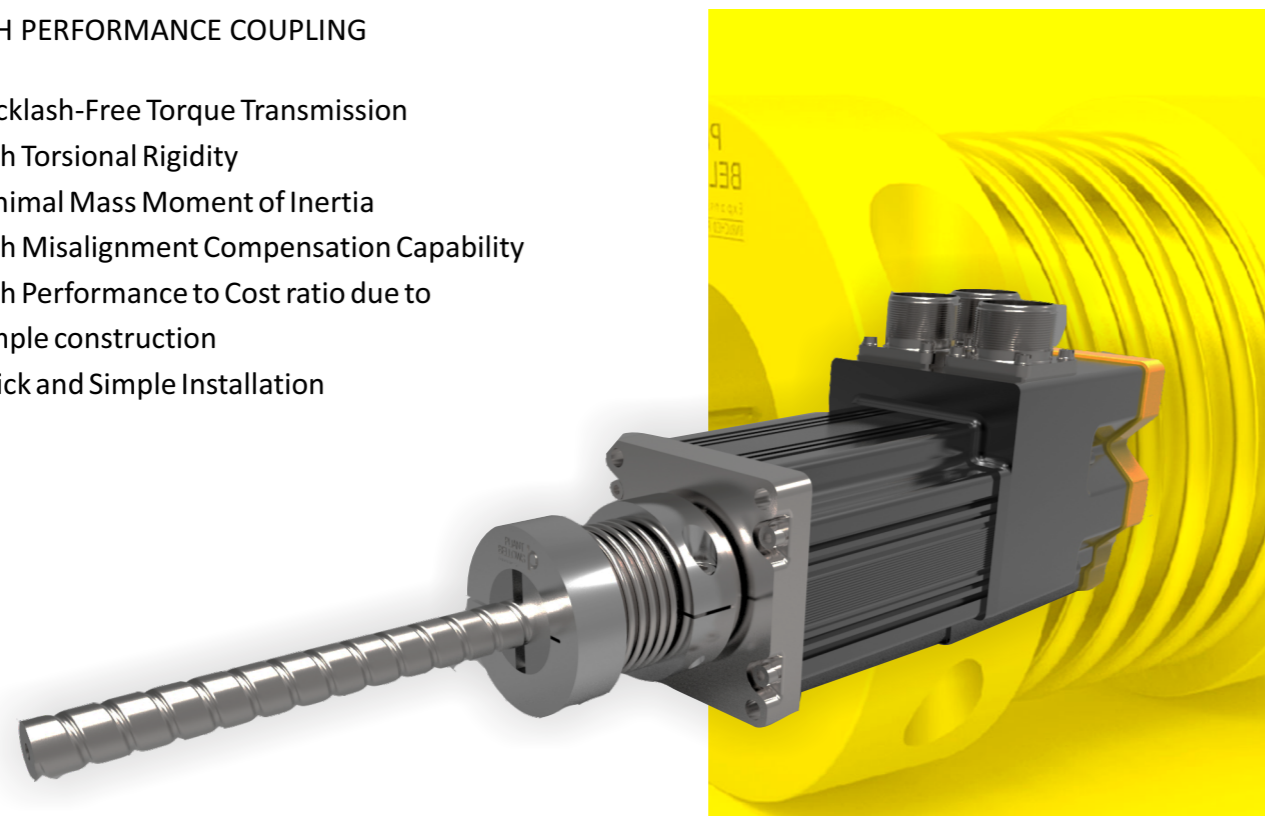

Coupling Size Selection

The following key factors should always be considered when specifying flexible shaft couplings:

Torque

Though, Couplings are normally sized for the highest torque to be regularly transmitted. The peak torque of the application should not exceed the rated torque of the coupling. The following calculation provides an approximation of the minimum required coupling size of the coupling for the application:

$$T_N \geq 1.5 T_{AS}$$

T_N = Rated torque of the coupling (Nm)
 T_{AS} = Peak torque of the drive system (e.g. Breakdown Torque of the Electric Motor)

Misalignment Requirements

The maximum misalignment of shafts is the largest allowed displacement between drive and output shaft, which results from the calculation of the prolonged alternating-stress strength for compensating elements. Determine the individual shaft misalignments and by using the "Permitted shaft misalignments" mentioned in table find the intended coupling size.

Installing Couplings

General Instructions-

1. Ensure that both the shafts are free of burrs, damage, or foreign matter, and can penetrate the bores.
2. Install the coupling by holding the shaft and the related hub, rotating it back and forth as you progress it along the shaft.
3. Do not apply any forces that cause extension, compression or lateral displacement of the coupling beyond its permissible offsets.

Installation Guidelines-

1. Position and secure the larger of the 2 shafts (if different) and progress the coupling onto it.

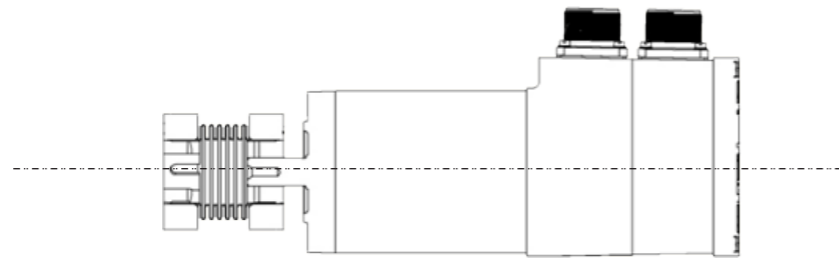

2. Progress the second shaft into the bore, taking care not to lever either shaft against the inner wall of the spacer.

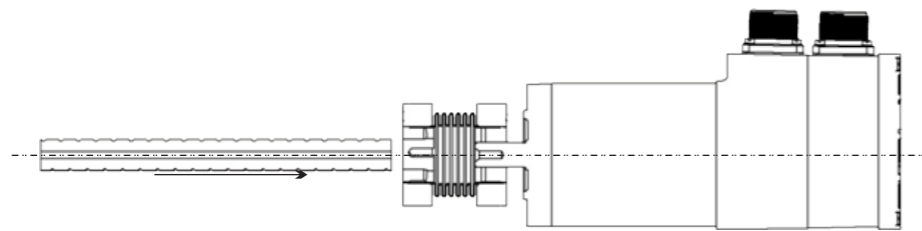

3. Progress the coupling along the shafts to a position midway between the shaft terminations. Rotate the coupling to ensure it is not binding and is in its natural state, i.e., neither extended nor compressed.

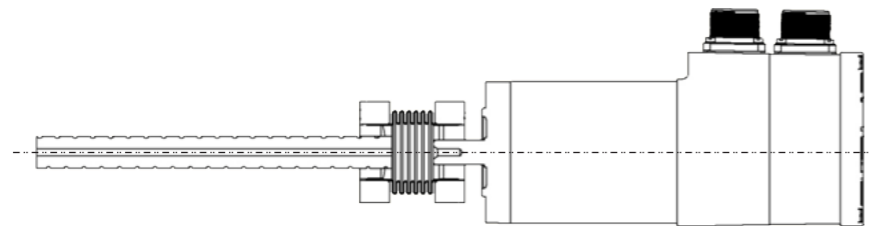

4. Align the second shaft with the first using a straight edge and feeler gauges or a dial indicator.
5. Secure the second shaft and re-check alignment. Final alignment must be within the permissible offsets.
6. Secure one hub, tightening each screw alternately. Repeat for the second hub.

Design And Manufacturing

The company has excellent capabilities in design and manufacturing of metal bellow couplings. The bellow design calculations are done by using competent software like EJMA and backed by rich experience of our designers. Renowned software's like SolidWorks and ANSYS are used to design and validate the concept. Apart from software's the couplings are physically tested for the performance characteristics.

The company understands the importance of having a well equipped tool room and inspection facility to support its production activities. Hence the company has invested in conventional and CNC machines from lathes, grinding to vertical machining centres. For the production activity the organisation has focused on developing SPM's as it believes that SPM's will help in achieving consistency, reliability

Total Deformation 3
Type: Total Deformation
Unit: mm
Time: 2

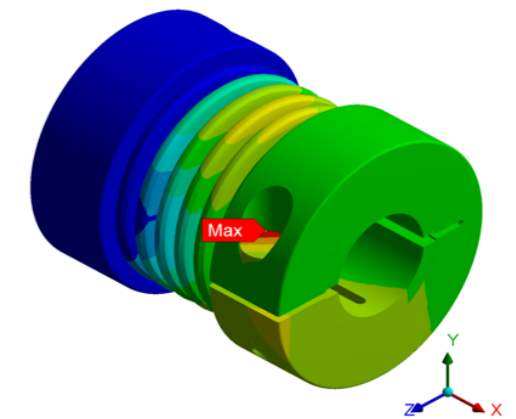
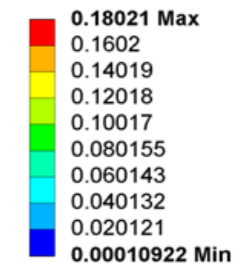

Applications

- | | |
|---------------------------------|---------------------------------|
| - Power Generation | - Oil & Gas |
| - Sugar Mill | - Engine Exhaust |
| - Infrastructure | - Solar Technology |
| - HVAC | - Chemical Industries |
| - Cryogenic | - Instrument & Valve Industries |
| - Steel Industries | - Water/ Waste Water |
| - Measurement & Control Systems | - Nuclear Plant |
| - Pulp & Paper | - Automobile Industries |

Testing Capabilities

- | | |
|--------------------------------------|------------------------------|
| - Hydrostatic Pressure and Leak Test | - Radiography Test |
| - Pneumatic Bubble Soap Leak Test | - X-Ray Test |
| - Vacuum Test | - Ultrasonic Test |
| - Dye Penetrant Test | - Helium Leak Detection Test |
| - Visual Test | |
| - Fatigue Test | |
| - Squirm Test | |
| - Spring Rate Test | |

Other Products



Axial Expansion Joints

These Joints are the simplest form of bellows manufactured. Pliant Bellows can manufacture them in single and multiple ply.

Pressure Switch Bellows

Pressure switches are designed to make electrical contact when a set pressure is reached. These switches can be designed to close or open, based on the pressure rising or falling.



Hinged Expansion Joints

When the angular movement is only in one plane, hinge or angular expansion joints are used. An angular expansion can be expressed when an expansion joint experience bending about its centre which is the centre line and half way between the ends of metal bellows.

Lateral Expansion Joints

Lateral expansion joints refers to the direction perpendicular to the centre line of the pipe expansion joint. Lateral deflection is also called as Parallel Offset and Transverse. The lateral expansion joints are also known as tied lateral expansion joints.



Inline Pressure Balanced Expansion Joints

An inline pressure balanced expansion joint accommodates axial and lateral movements and counteracts the bellows pressure thrust.



Universal Expansion Joints

Universal expansion joints are made up of 2 elements of bellows joined together by a common spool piece so it is also called as Double Bellows Expansion Joint or Universal Bellows.



Pressure Balanced (Elbow) Expansion Joints

An Elbow Pressure Balanced Expansion Joint is designed to absorb externally imposed axial movement without imposing pressure loading on the system.



Gimbal Expansion Joints

The gimbal expansion joints are the most reliable expansion joint since it is capable of absorbing angular motion in all the

Customer: Sr.No: Date:

Email Id: Mob. No.: PO No:

Type of Bellow Coupling	BC1.....BC2:BC3: BC4:BC5:
Bellow Material	Material:No of Ply: Ply Thickness:
Bore Diameter	d1(mm):..... d2(mm).....
Length (L)	In mm:
Torque (T)	In Nm :.....
Speed (S)	In rpm :.....
Part Number	BC Sr.No- dmin- dmax- Length- Torque- Speed

Part Number Generation:

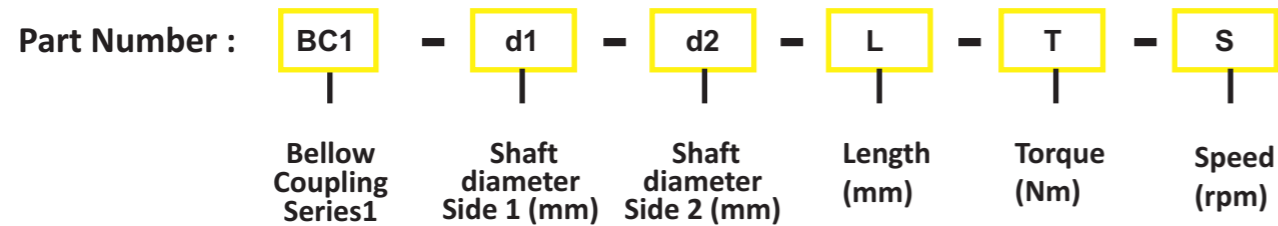

Eg. : BC1 - 14 - 18 - 58 - 10 - 8000

Email Id: mktg@pliantbellows.com

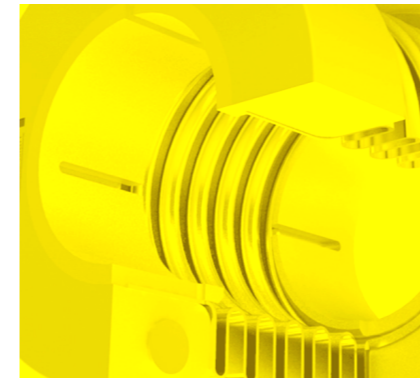



KWALITY PRODUCTS
ISO 9001:2015

Corporate Office
Final Plot No.38/1, Ramtekdi
Industrial Estate, Hadapsar, Pune,
Maharashtra, India- 411013

Phone
+91-20-2681 4175
+91-70289 97949
+91-98904 54224

Email
mktg@pliantbellows.com
anand.uttarkar@pliantbellows.com
priya.bagul@pliantbellows.com

Website: www.pliantbellows.com

